

A50

Your simple CO₂ solution

by **ANALOX**



The A50 is a simple wall mountable CO₂ monitor for confined spaces that use carbon dioxide including bars, restaurants, cellars and single room laboratories or research facilities.

The A50 uses a single CO₂ sensor to detect an increase of gas and triggers an alarm if dangerous levels are detected. Alarm set points are set as default as TWA, 1.5% and 3% CO₂.

Alarms will sound and flash on the sensor unit if levels of CO₂ start to increase. The supplied alarm repeater unit, which should be installed outside of the room where the sensor unit is installed, will mimic what the sensor unit is displaying to warn people before they enter the risk area.

Worldwide workplace and health and safety standards recommend that employees should not be exposed to increased levels as CO₂ as it can be lethal in large quantities. **EH40 in Europe** and **OSHA in the USA provide guidelines on CO₂ exposure limits** and ensure CO₂ detection and alarm systems are in place.

Applications

- Restaurants & Fast food establishments
- Pubs & Bars
- Breweries & Wineries
- Greenhouses & Agriculture
- Labs
- Medical
- Fire Suppression
- Schools & Academic facilities
- Green Energy
- Gas Manufacturing & Blending
- Confined spaces

Gases Detected

Carbon Dioxide (CO₂)

Features

- Simple single point CO₂ sensor
- Alarm Repeater for pre-warning
- Easy to operate
- Audio/visual alarm
- Fitted with TWA (Time Weighted Average) alarm
- 5 year CO₂ sensor warranty
- 5 year electronic warranty

Want to talk about your
application requirements?
Give Us a call!

Your Challenge, **Our Passion**

Speak to our team **today**
UK/Global: +44 (0)1642 711 400
US Office: (714) 891 4478

A50

Tech Spec

Alarm Repeater

Sounder	Min 75 dBA at a distance of 10cm
Internal Strobe	Intensity >10cd
Dimensions	1.7"/45mm x 5.1"/132mm x 3"/72mm (w x h x d)

CO2 Sensor Unit

Measurement technique	Infrared
Range	0.1% to 5%
Operating Temperature	-5 to +40°C
Default alarm set-points	TWA, 1.5% & 3%
IP Rating	IP65
Warranty	5 years
Response time	60 seconds to T90
Dimensions	6.9"/175mm x 4"/106mm x 2.6"/67mm (w x h x d)

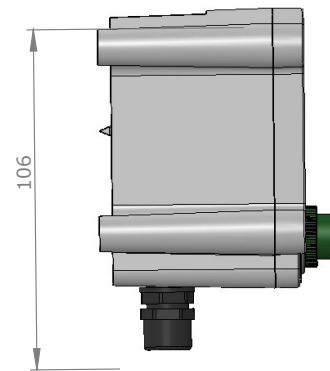
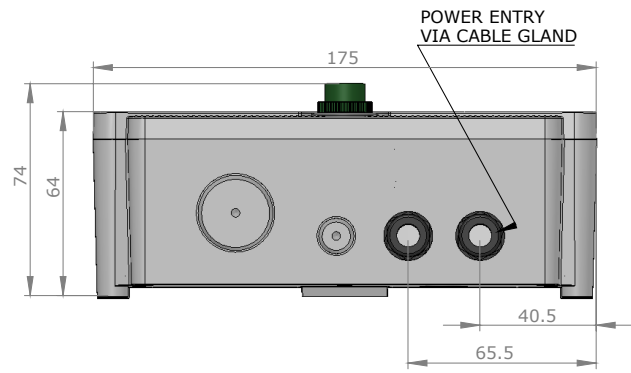
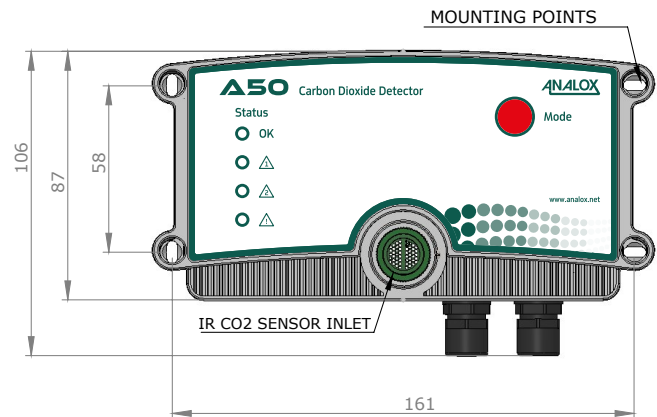

FACT

Dry Ice is CO₂ in its solid form, using dry ice has the same health risks as using cylinders of CO₂.

You can call us

UK/Global: +44 (0)1642 711 400
US Office: (714) 891 4478

You can email us

info@analogxgroup.com

Visit our website

analogxgroup.com

Follow us on

ANALOX

Your Challenge, **Our Passion**